



CHONGQING CLOUDCHILD TECHNOLOGY CO.,LTD
TO-252-2L Plastic-Encapsulate MOSFETS

CCM90N4-C **N-Channel Power MOSFET**

$V_{(BR)DSS}$	$R_{DS(on)TYP}$	I_D
40 V	1.8mΩ@10V	90A

DESCRIPTION

The CCM90N4-C uses advanced trench technology and design to provide excellent $R_{DS(ON)}$ with low gate charge. It can be used in a wide variety of applications .

FEATURES

- Excellent package for good heat dissipation
- Ultra low gate charge
- Low reverse transfer capacitance
- Fast switching capability
- Avalanche energy specified
- AEC Q101 qualified

APPLICATIONS

- Power switching application

MARKING



CCM90N4-C =Part No.
 XXXXXXX = Code.

EQUIVALENT CIRCUIT

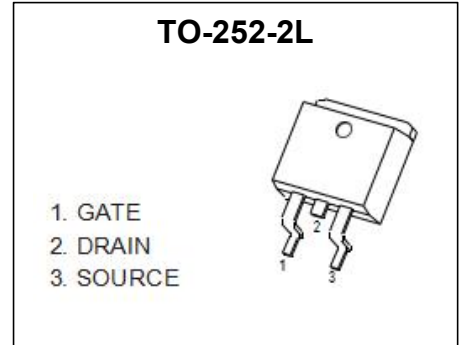
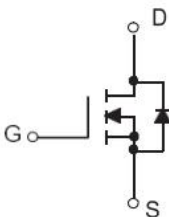

ABSOLUTE MAXIMUM RATINGS($T_c=25^{\circ}\text{C}$ unless otherwise noted)

Parameter	Symbol	Limit	Unit
Drain-Source Voltage	V_{DS}	40	V
Gate-Source Voltage	V_{GS}	± 20	V
Continuous Drain Current ¹	I_D	90	A
Pulsed Drain Current ²	I_{DM}	360	A
Single Pulse Avalanche Energy ³	EAS	400	mJ
Total Power Dissipation ¹	P_D	83	W
Thermal Resistance from Junction to Case ¹⁴	$R_{\theta JC}$	1.8	$^{\circ}\text{C}/\text{W}$
Operating Junction and Storage Temperature Range	T_J, T_{STG}	-55~ +175	$^{\circ}\text{C}$
Soldering Temperature , for 10S(1.6mm from case)	-	260	$^{\circ}\text{C}$

Notes:

1. Current is limited by bondwire, with an $R_{\theta JC}=1.8^{\circ}\text{C}/\text{W}$ the chip is able to carry 154A at 25°C .
2. $P_w \leq 10\mu\text{s}$, Duty cycle $\leq 1\%$.
3. EAS condition: $V_{DD}=20\text{V}, V_{GS}=10\text{V}, I_{as}=40\text{A}, L=0.5\text{mH}, R_g=25\Omega$ Starting $T_J=25^{\circ}\text{C}$.
4. The value of $R_{\theta JC}$ is measured with the device mounted on 1 in 2 FR-4 board with 2oz. Copper, in a still air environment with $T_a=25^{\circ}\text{C}$.

MOSFET ELECTRICAL CHARACTERISTICS

TC=25°C unless otherwise specified

Parameter	Symbol	Test Condition	Min	Typ	Max	Unit
Off characteristics						
Drain-source breakdown voltage	$V_{(BR)DSS}$	$V_{GS} = 0V, I_D = 250\mu A$	40			V
Zero gate voltage drain current	I_{DSS}	$V_{DS} = 40V, V_{GS} = 0V, T_J = 25^\circ C$			1	μA
Gate-body leakage current	I_{GSS}	$V_{DS} = 0V, V_{GS} = \pm 20V$			± 100	nA
On characteristics⁴						
Gate-threshold voltage	$V_{GS(th)}$	$V_{DS} = V_{GS}, I_D = 250\mu A$	1.5	1.7	2.5	V
Static drain-source on-state resistance	$R_{DS(on)}$	$V_{GS} = 10V, I_D = 90A$		1.8	2.5	m Ω
		$V_{GS} = 4.5V, I_D = 20A$		2.5	3.0	m Ω
Forward transconductance	g_{fs}	$V_{DS} = 10V, I_D = 10A$		95		S
Dynamic characteristics³⁴						
Input capacitance	C_{iss}	$V_{DS} = 25V, V_{GS} = 0V, f = 1MHz$		3730	4850	pF
Output capacitance	C_{oss}			1019	1325	
Reverse transfer capacitance	C_{rss}			62	85	
Gate resistance	R_g	$f = 1MHz$		2.2		Ω
Switching characteristics³⁴						
Total gate charge	Q_g	$V_{GS} = 0-10V, V_{DD} = 32V, I_D = 90A$		52		nC
Gate-source charge	Q_{gs}			28		
Gate-drain charge	Q_{gd}			16		
Turn-on delay time	$t_{d(on)}$	$V_{DD} = 20V, I_D = 90A, V_{GS} = 10V, R_G = 3.5\Omega$		15		ns
Turn-on rise time	t_r			18		
Turn-off delay time	$t_{d(off)}$			55		
Turn-off fall time	t_f			30		
Drain-Source Diode Characteristics						
Drain-source diode forward voltage ⁴	V_{SD}	$V_{GS} = 0V, I_S = 90A$			1.2	V
Continuous drain-source diode forward Current ¹	I_S	-			90	A
Pulsed drain-source diode forward current ²	I_{SM}	-			360	A
Reverse recovery time	T_{rr}	$I_F = 50A, V_R = 20V, dI/dt = 100A/\mu s$			50	ns
Reverse recovery charge	Q_{rr}				38	nC

Note :

1. Current is limited by bondwire, with an $R_{\theta JC} = 1.8^\circ C/W$ the chip is able to carry 154A at 25°C.
2. $P_w \leq 10\mu s$, Duty cycle $\leq 1\%$.
3. Guaranteed by design, not subject to production.
4. Pulse Test : Pulse Width $\leq 300\mu s$, duty cycle $\leq 2\%$.

Typical Characteristics

PD -- Tc

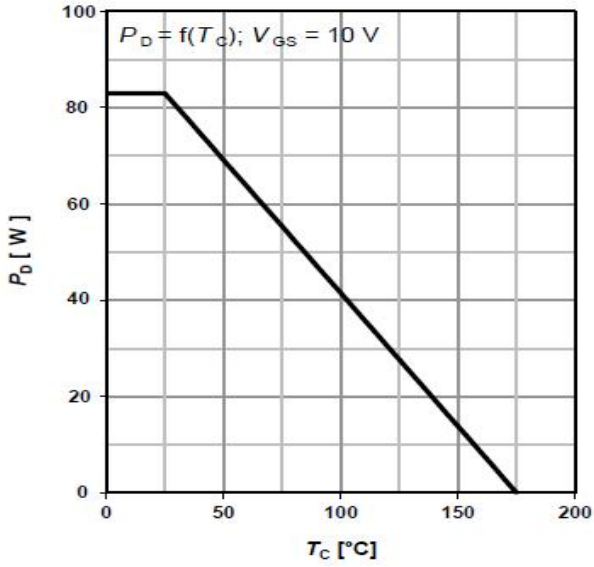

ID -- Tc

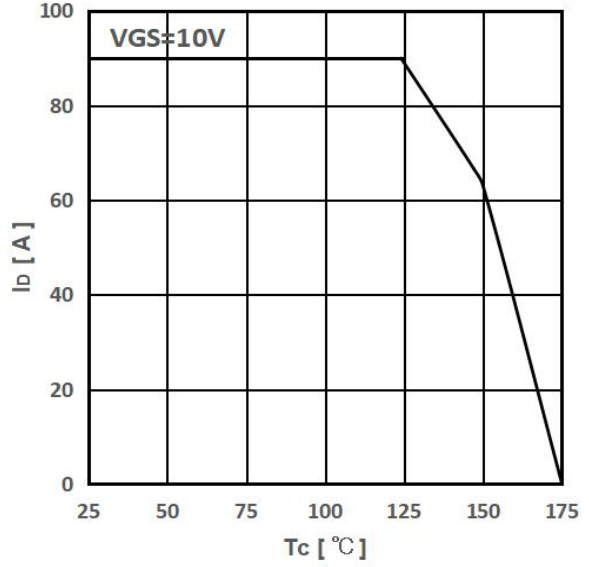

ID -- VDS

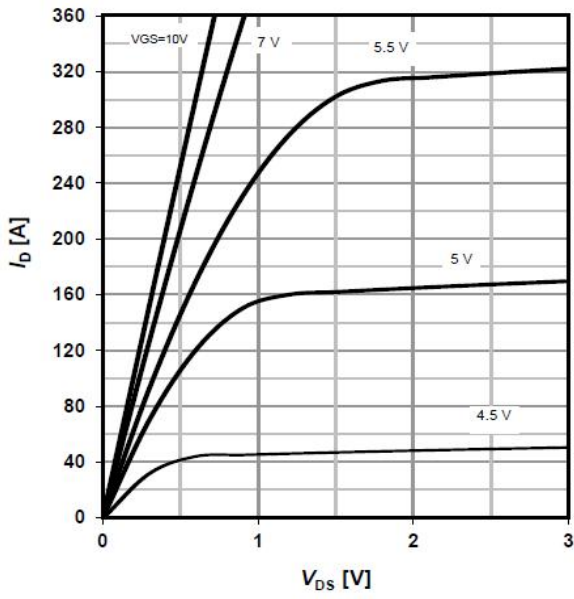

ID -- VGS

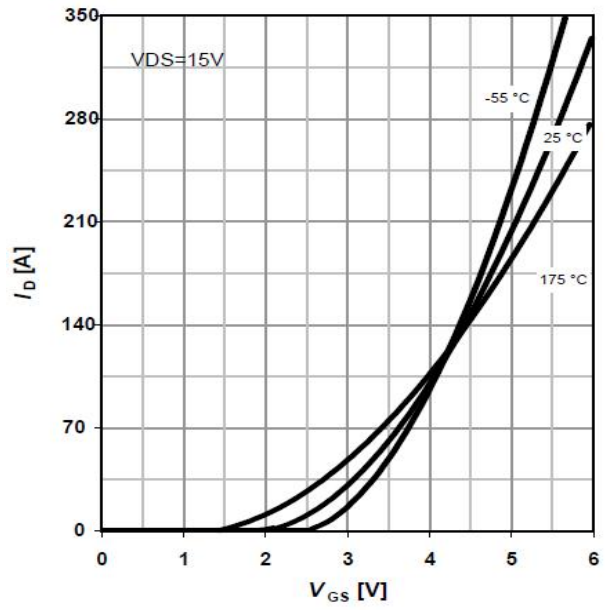

RDS(on) -- ID

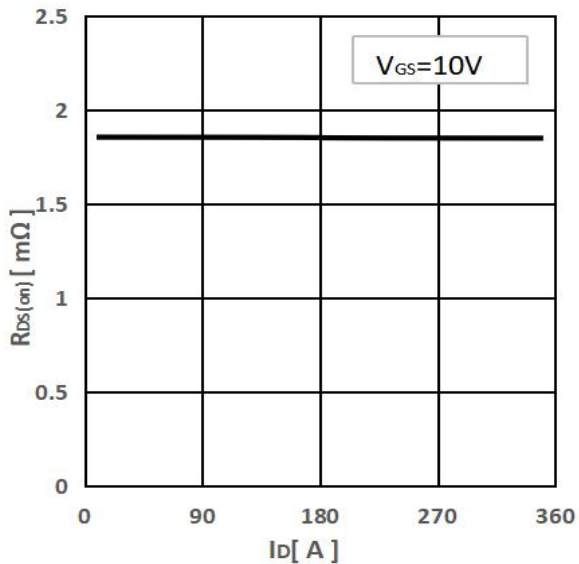

IS -- VSD

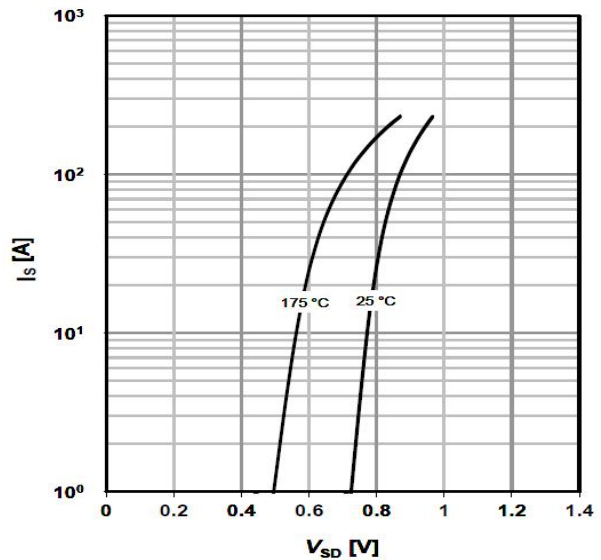

RDS(on) -- VGS

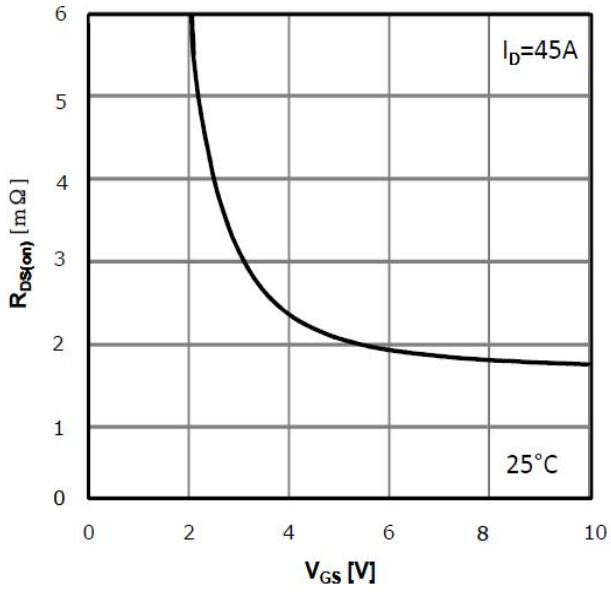

Threshold Voltage

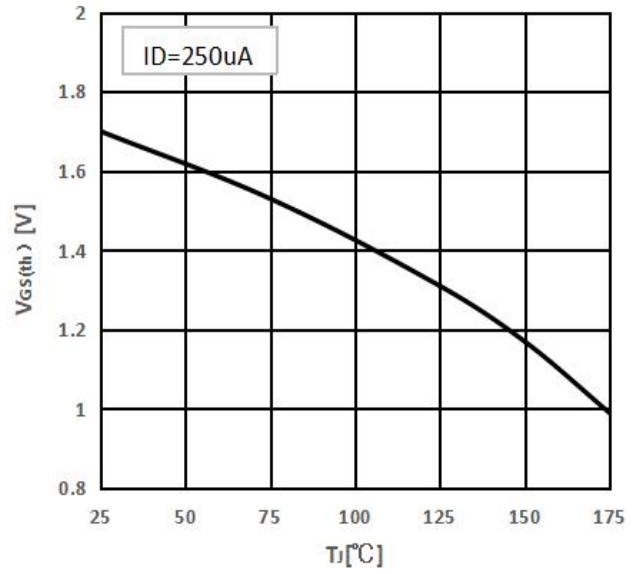

Drain-source breakdown voltage

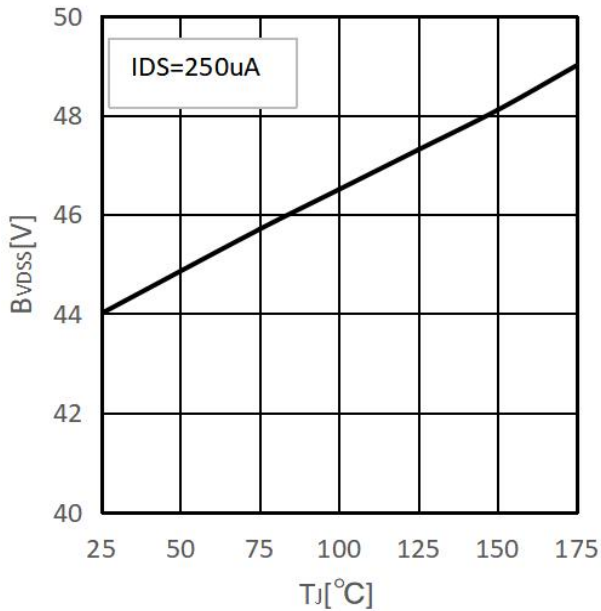

RDS (on) -- Tj

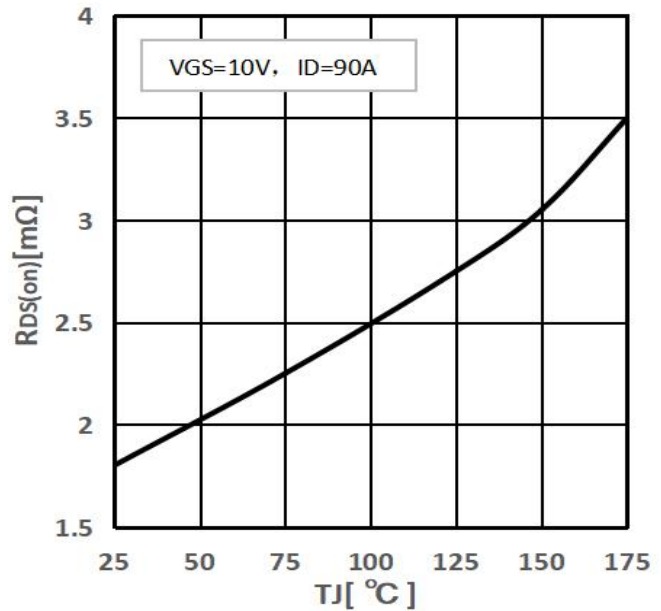

Typ.gate charge

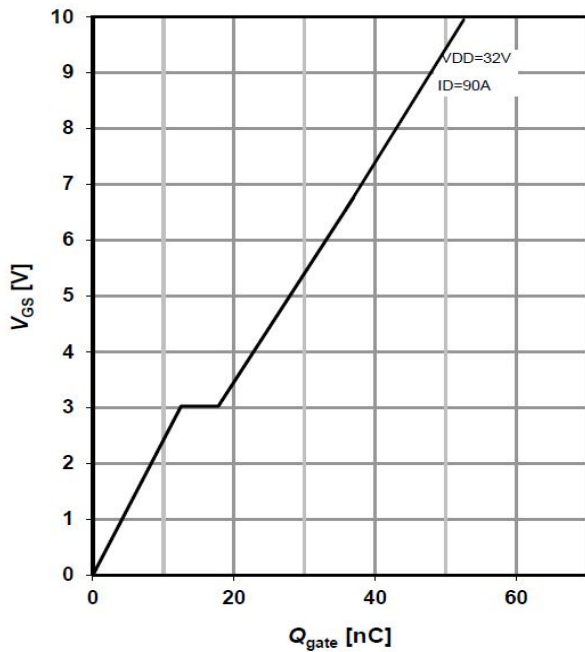

Avalanche energy

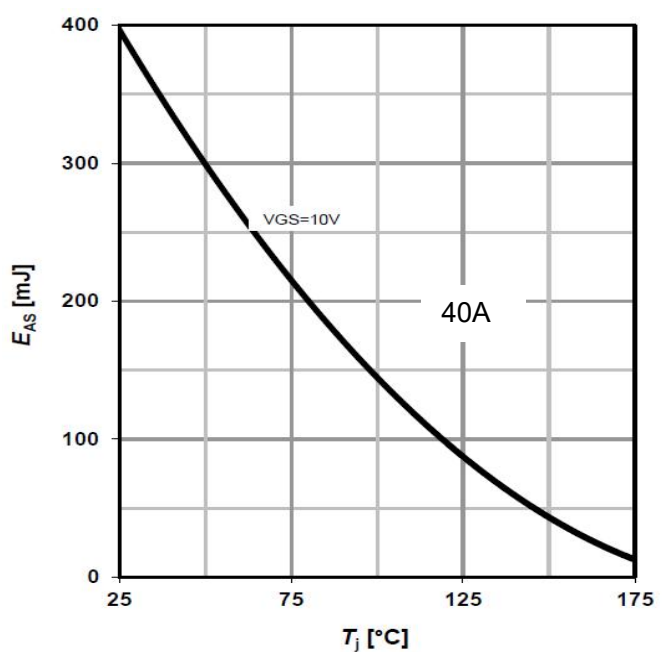

Typ. capacitance

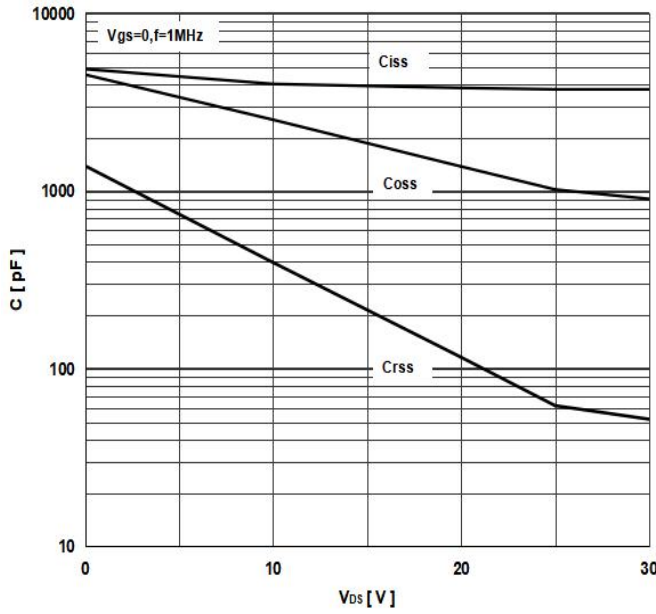

Gate charge waveforms

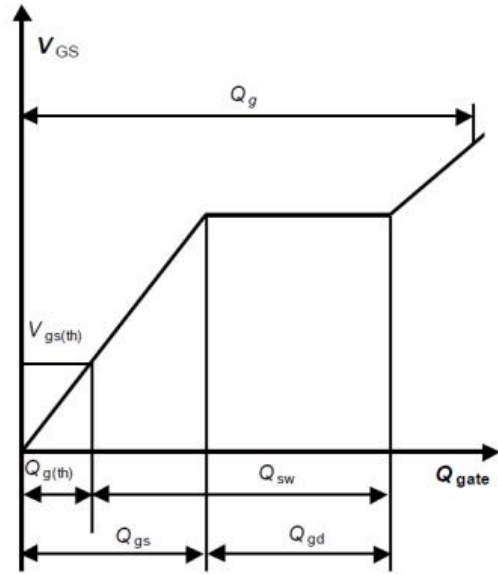

Maximum Forward Biased Safe Operating Area

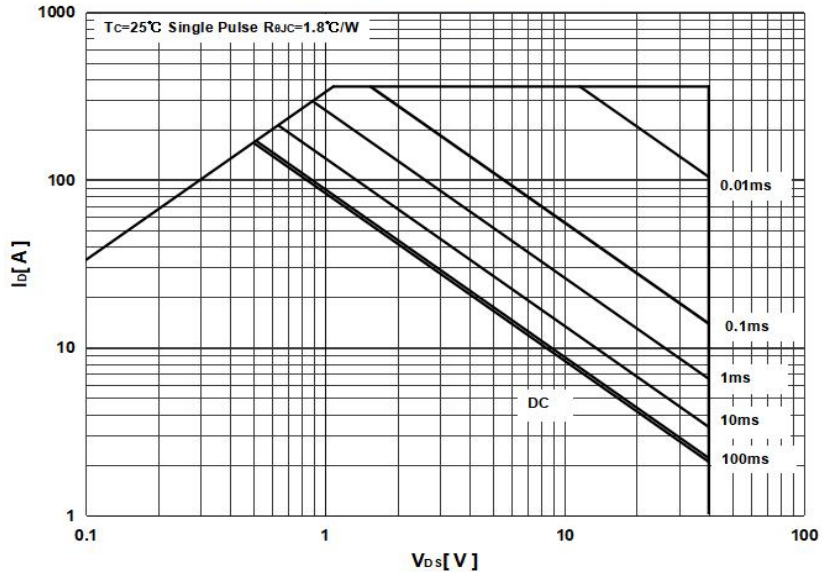

Normalized Thermal Transient Impedance

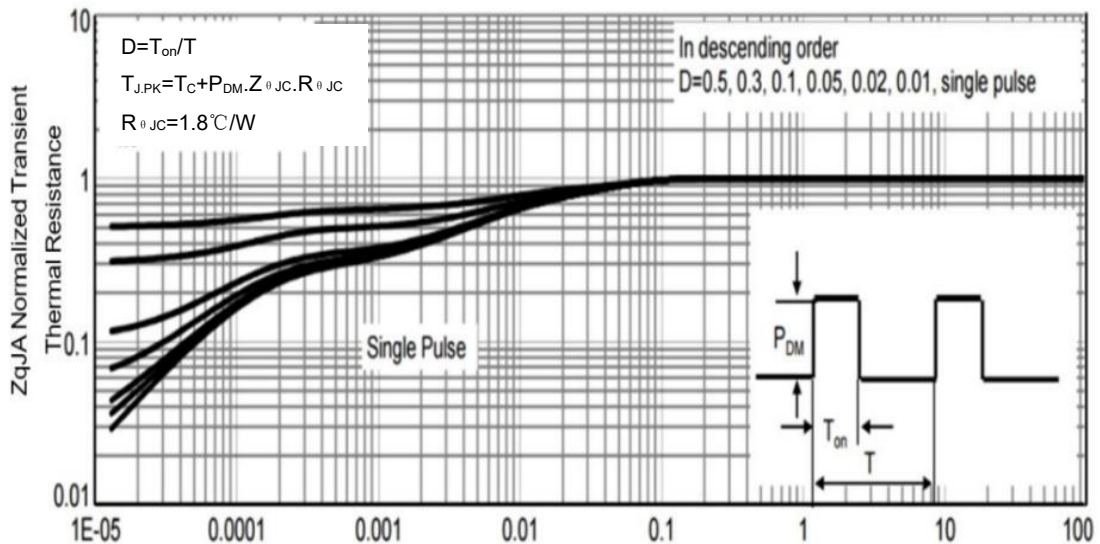

TO-252-2L Package Outline Dimensions

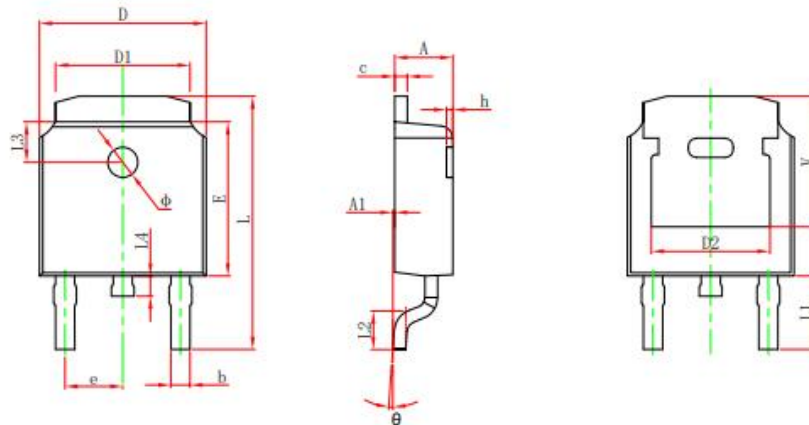

Symbol	Dimensions In Millimeters		Dimensions In Inches	
	Min.	Max.	Min.	Max.
A	2.200	2.400	0.087	0.094
A1	0.000	0.127	0.000	0.005
b	0.635	0.770	0.025	0.030
c	0.460	0.580	0.018	0.023
D	6.500	6.700	0.256	0.264
D1	5.100	5.460	0.201	0.215
D2	4.830 REF.		0.190 REF.	
E	6.000	6.200	0.236	0.244
e	2.186	2.386	0.086	0.094
L	9.712	10.312	0.382	0.406
L1	2.900 REF.		0.114 REF.	
L2	1.400	1.700	0.055	0.067
L3	1.600 REF.		0.063 REF.	
L4	0.600	1.000	0.024	0.039
Phi	1.100	1.300	0.043	0.051
theta	0° to 8°		0° to 8°	
h	0.000	0.300	0.000	0.012
V	5.250 REF.		0.207 REF.	

TO-252-2L Suggested Pad Layout

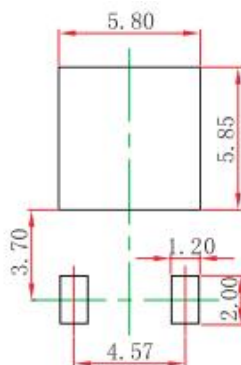

Note:

1. Controlling dimension: in millimeters.
2. General tolerance: 0.5mm.
3. The pad layout is for reference purposes only.

NOTICE

Cloudchild reserve the right to make modifications, enhancements, improvements, corrections or other changes without further notice to any product herein. Cloudchild does not assume any liability arising out of the application or use of any product described herein.

ChongQing Cloudchild Technology Co., Ltd. (short for Cloudchild) exerts the greatest possible effort to ensure high quality and reliability. Nevertheless, semiconductor devices in general can malfunction or fail due to their inherent electrical sensitivity and vulnerability to physical stress. It is the responsibility of the buyer, when utilizing Cloudchild products, to comply with the standards of safety in making a safe design for the entire system, including redundancy, fire-prevention measures, and malfunction prevention, to prevent any accidents, fires, or community damage that may ensue. In developing your designs, please ensure that Cloudchild products are used within specified operating ranges as set forth in the most recent Cloudchild products specifications.

TO-252-2L Tape and Reel

TO-252 Embossed Carrier Tape

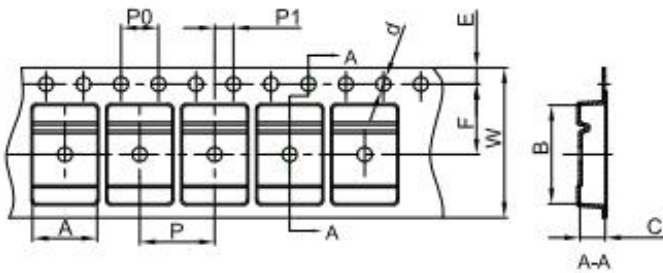

Packaging Description:

TO-252 parts are shipped in tape. The carrier tape is made from a dissipative (carbon filled) polycarbonate resin. The cover tape is a multilayer film (Heat Activated Adhesive in nature) primarily composed of polyester film, adhesive layer, sealant, and anti-static sprayed agent. These reeled parts in standard option are shipped with 25,00 units per 13" or 33.0 cm diameter reel. The reels are clear in color and is made of polystyrene plastic (anti-static coated).

Dimensions are in millimeter											
Pkg type	A	B	C	d	E	F	P0	P	P1	W	
TO-252	6.90	10.50	2.70	Ø1.55	1.75	7.50	4.00	8.00	2.00	16.00	

TO-252 Tape Leader and Trailer

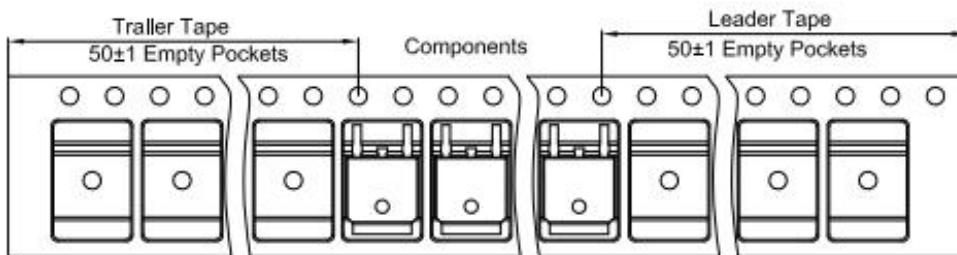

TO-252 Reel

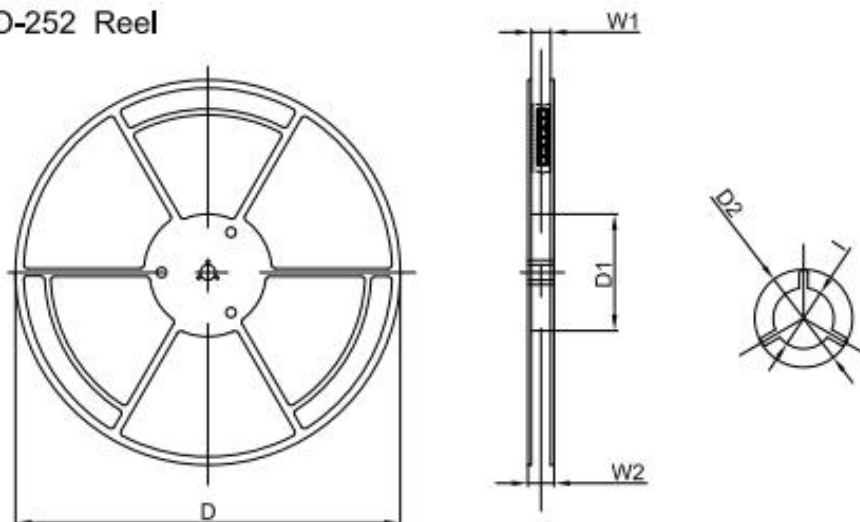

Dimensions are in millimeter						
Reel Option	D	D1	D2	W1	W2	I
13"Dia	330.00	100.00	Ø21.00	16.40	21.00	Ø13.00

REEL	Reel Size	Box	Box Size(mm)	Carton	Carton Size(mm)	G.W.(kg)
2,500 pcs	13Inch	2,500 pcs	340×336×29	25,000 pcs	353×346×365	

Date of change	Rev #	revise content
2022/12/02	A/0	/
2024/01/08	A/1	微调产品实测参数（提高测试电流），增加结电容上限